

Kelvion

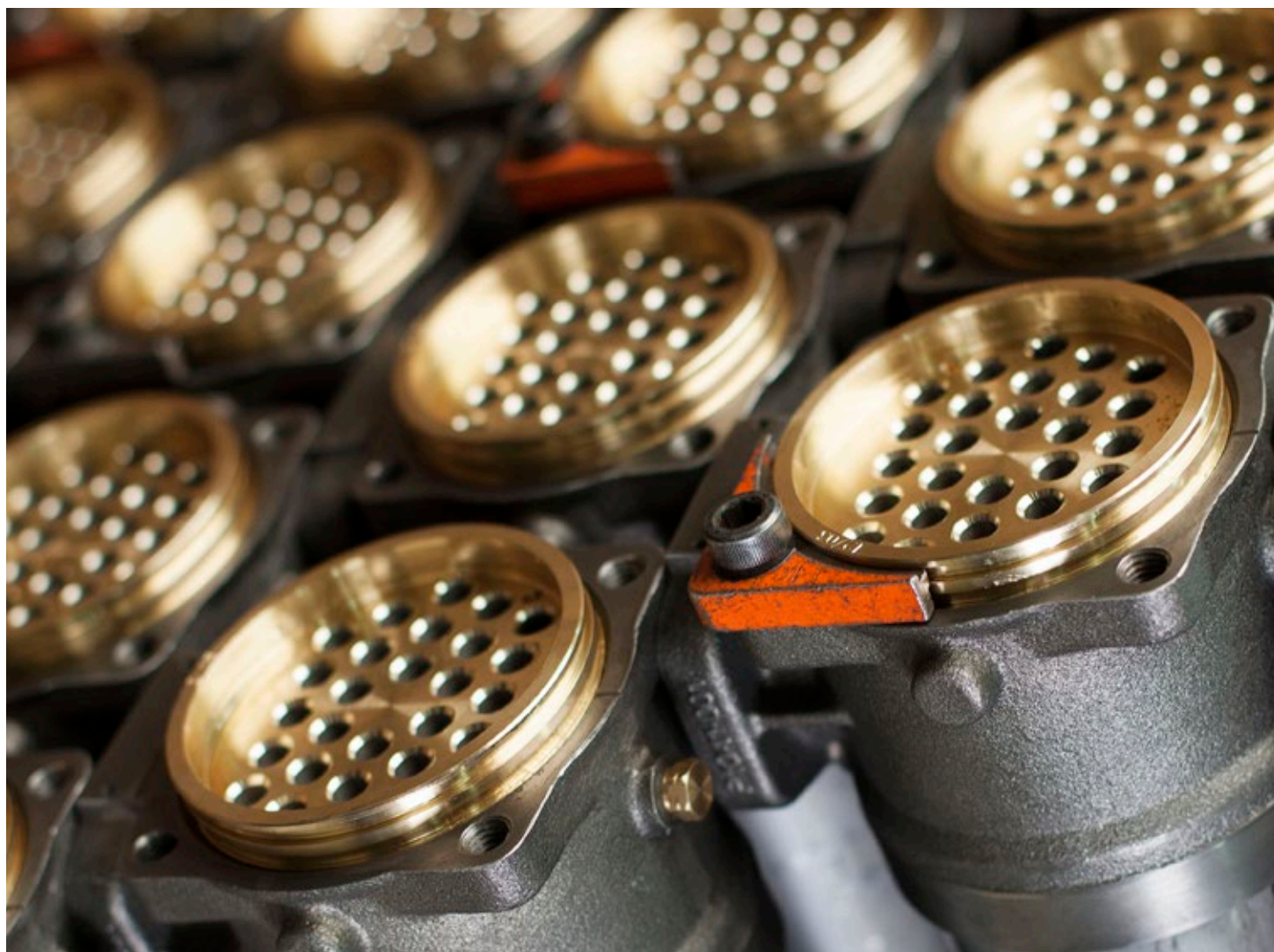

Shell & Tube Single ComFin

# ENHANCED DESIGN AND PERFORMANCE



Kelvion



# EXPERTS IN HEAT EXCHANGE – SINCE 1920

Welcome to Kelvion. Heat exchange is our business. Worldwide. As a market leader in the technology sector, we have been producing heat exchangers for virtually every conceivable industrial application since the 1920s, including tailor-made solutions suited for the most complex environmental conditions – as of 2015 under the name of Kelvion.

With one of the most comprehensive ranges of heat exchangers in the world, which includes compact finned-tube heat exchangers, plate heat exchangers, single tube heat exchangers, shell and tube heat exchangers, transformer cooling systems and wet cooling towers, we are a sought after partner in a wide variety of industries, such as: the energy industry, the oil and gas industry, the chemical industry, the shipbuilding sector, the food and beverage industry, the heavy industry, the sugar industry, the transport sector, as well as building and refrigeration technology.

Many years of experience and in-depth expert knowledge make us specialists in this field. Our heat exchangers are designed for the requirements of the respective process, thereby ensuring optimum energy efficiency and reliability for all market segments. This provides our customers with a technological advantage that reduces operating costs and has a lasting effect.

A reliable after-sales service is essential with regard to customer loyalty and retention. We have a worldwide service network at our disposal. Our engineers are thereby able to carry out maintenance work and complete repairs on-site at a customer's premises. This prevents unnecessary downtime – because we are highly committed to earning your trust.

Kelvion – Experts in Heat Exchange.

## KELVION – A TRIBUTE TO LORD KELVIN (1824 - 1907)



Lord Kelvin formulated the laws of thermodynamics and absolute units of temperature are stated in kelvin, in his honor.

## OUR LOGO – INSPIRED FROM THE SCHEMATIC FOR HEAT EXCHANGER

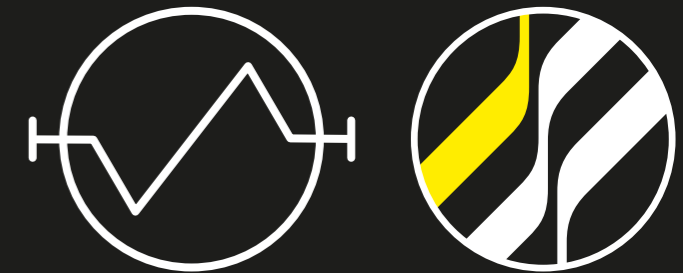

## 67 BRANCHES AND SALES PARTNERS WORLDWIDE

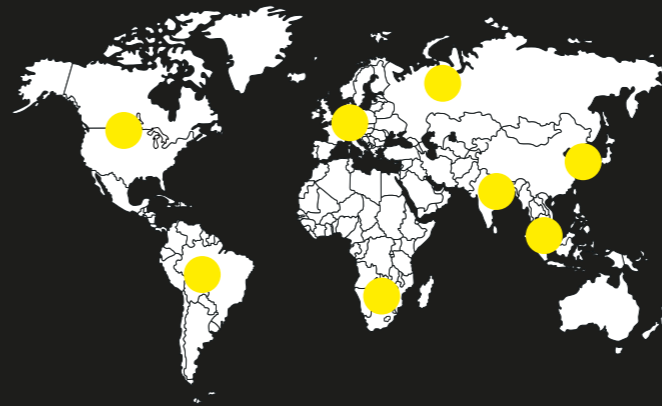

## 4,500 EMPLOYEES WORLDWIDE



## YOUR MARKETS ARE OUR MARKETS

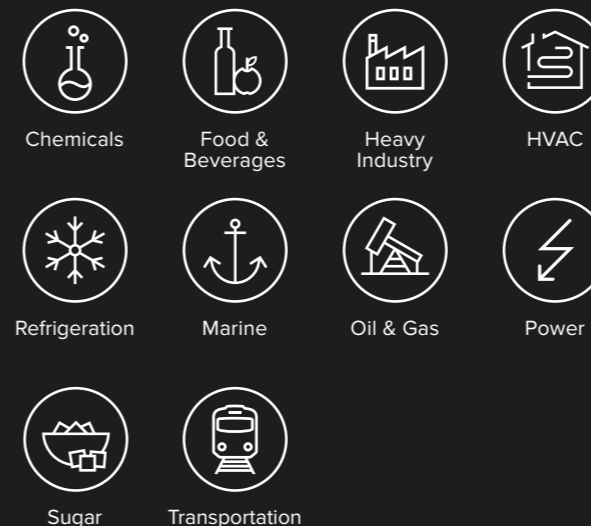

## KELVION HAS A LONG HISTORY





# S&T SINGLE ComFin OVERVIEW

## S&T Single ComFin P - Series

Standardized shell design

- PF Type
- PFR Type

## S&T Single ComFin N - Series

Customized shell design

- NF Type

## S&T Single ComFin

Special solutions

## S&T Single ComFin

Insert Bundles

Kelvion Shell & Tube Single ComFin combines the advantages of a shell & tube heat exchanger with a compact fin design, resulting in a highly efficient and space-saving solution. You can choose a standardized or customized design to best suit your application.

Single tubes and special fins are built together in one robust cooler bundle. This construction, together with optimized tolerances, produces a highly efficient and compact heat exchanger – up to 75% smaller than a conventional tubular heat exchanger with plain tubes.

This heat exchanger type offers major advantages for applications where oil or air has to be cooled. The enlarged surface on the shell side compensates the lower heat transfer value of such media.

It is ideal for customers who require a reliable, low-maintenance and high-quality heat exchanger that is also long-lasting and takes up minimum space. Due to its robust cylindrical design the heat exchangers have good resistance to vibrations and shock loads.

The Kelvion Shell & Tube Single Comfin is available as P-Series and N-Series. The P-Series covers standardized shell design while the N-Series provides customized welded shell design. We can also provide special solutions, fully tailored to your individual needs, as well as insert bundles to integrate into your equipment and machines.

- ▶ Excellent track record
- ▶ Proven cooler concept
- ▶ Global presence and service network
- ▶ Ongoing research and development work

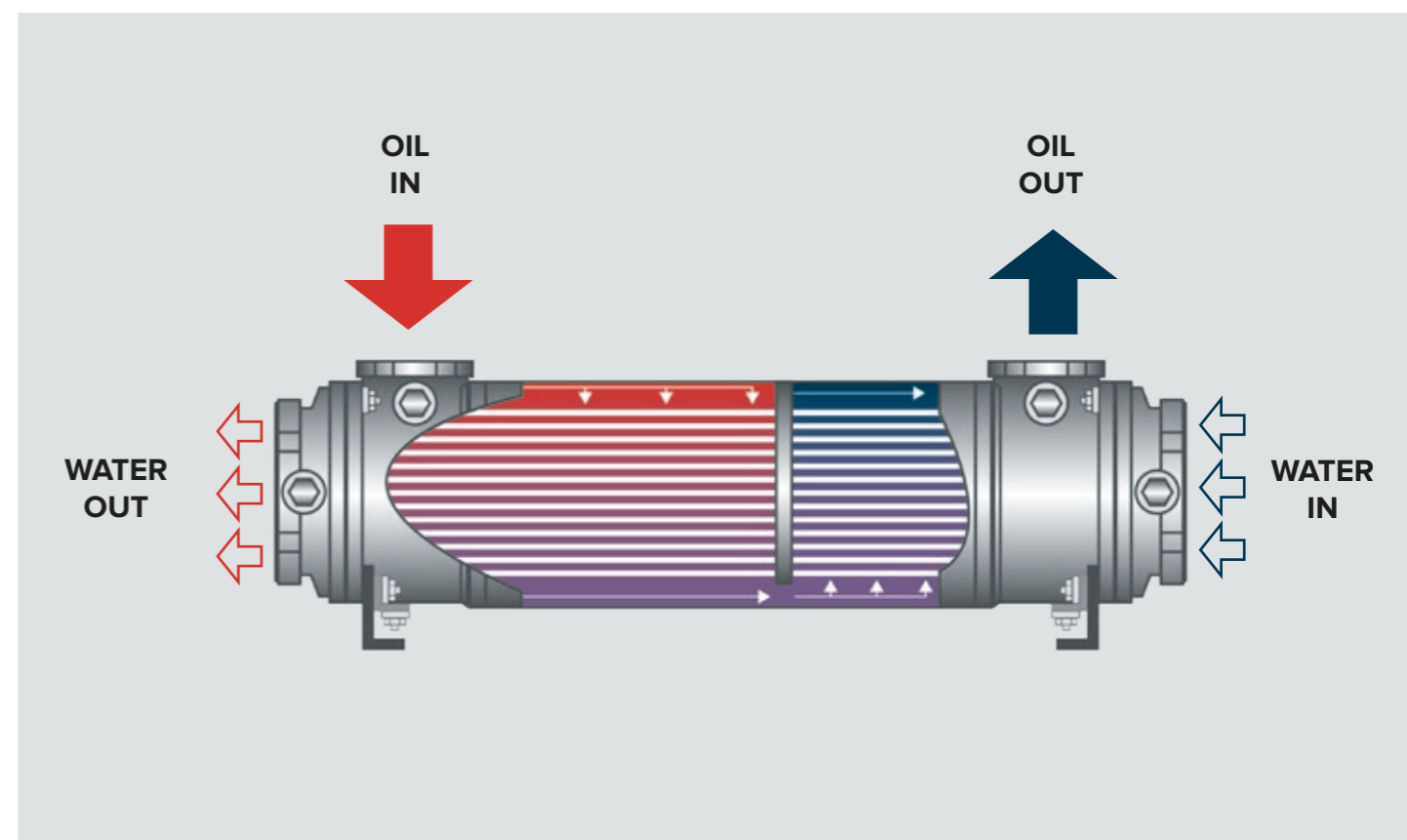



# S&T SINGLE ComFin - PF

## The standardized solution for oil and air cooling

The PF Type, which combines a P Type shell with a compact fin bundle, is the standardized, short-delivery product for various oil and air cooling applications.

The heat exchanger shell consists of a steel pipe with cast end pieces at each side, which are bonded together mechanically. A non-welded mechanical connection provides accurate tolerances. The shells are resistant to pressures up to 25 bar.

We can provide different shell diameters and lengths to suit a wide range of design requirements. The individual combination of shell size, tube bundle executions and various connection types for the primary and secondary side makes each heat exchanger one of a kind, custom-built to your application.

On the tube side you can choose 1, 2 or 3 pass executions to select the right layout and size for your system. Different materials for the shell, the connection parts, the tubes and the

finns are available to meet the requirements of varying cooling water qualities (such as closed circuit water, clean water, open water or sea water). The version for open water and sea water is equipped with sacrificial anodes to protect the bundle against corrosion. The double O-ring construction makes it possible to inspect the tube side while the shell side remains pressurized. This feature also prevents intermixing of fluids in the event of damage to the O-ring. Additionally, the fin pitch of the compact fin bundle can be adapted to the media of your process.

The modular design results in compact and efficient shell & tube heat exchangers. In addition, short production lead times and lean production processes guarantee cost efficiency.

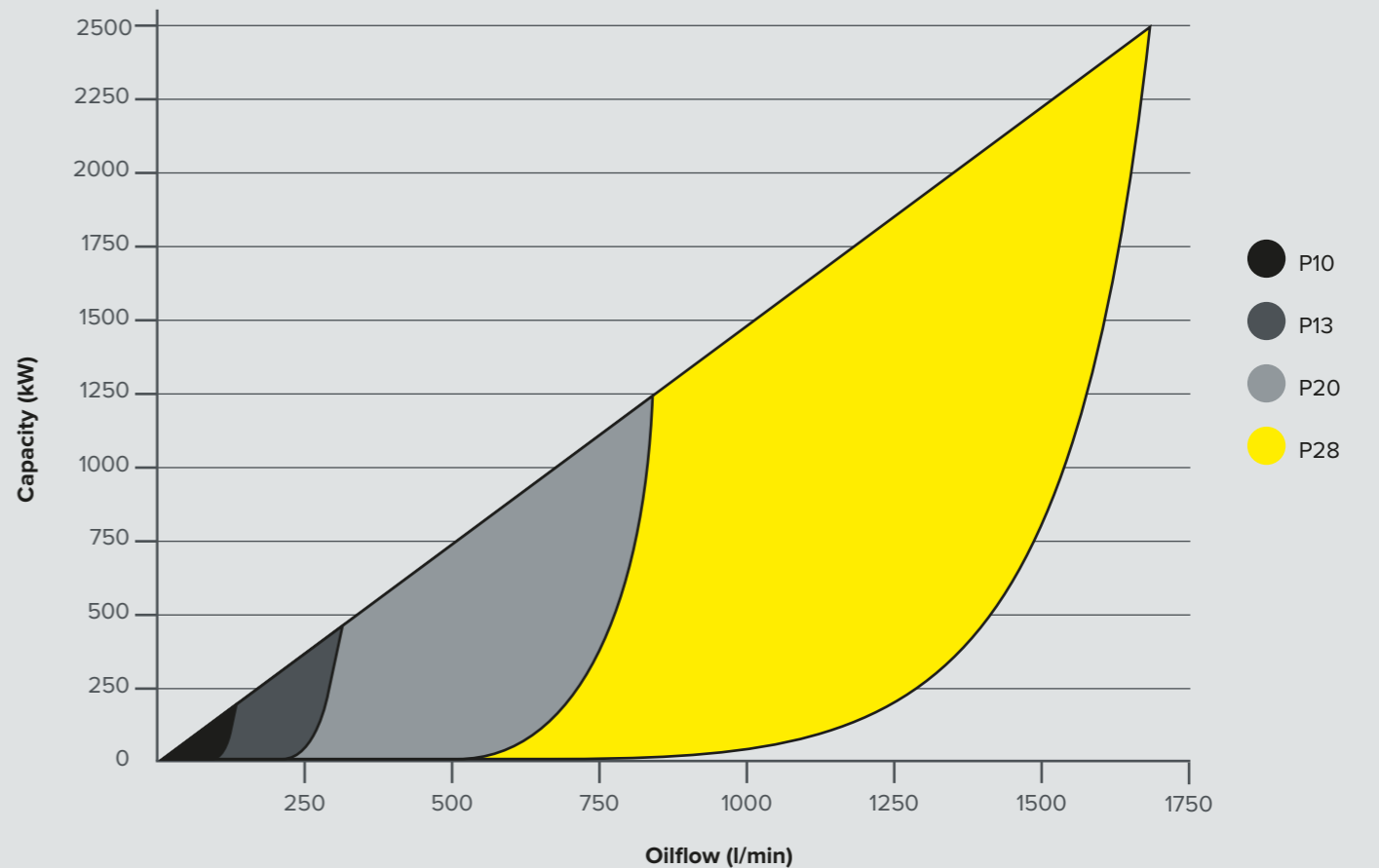
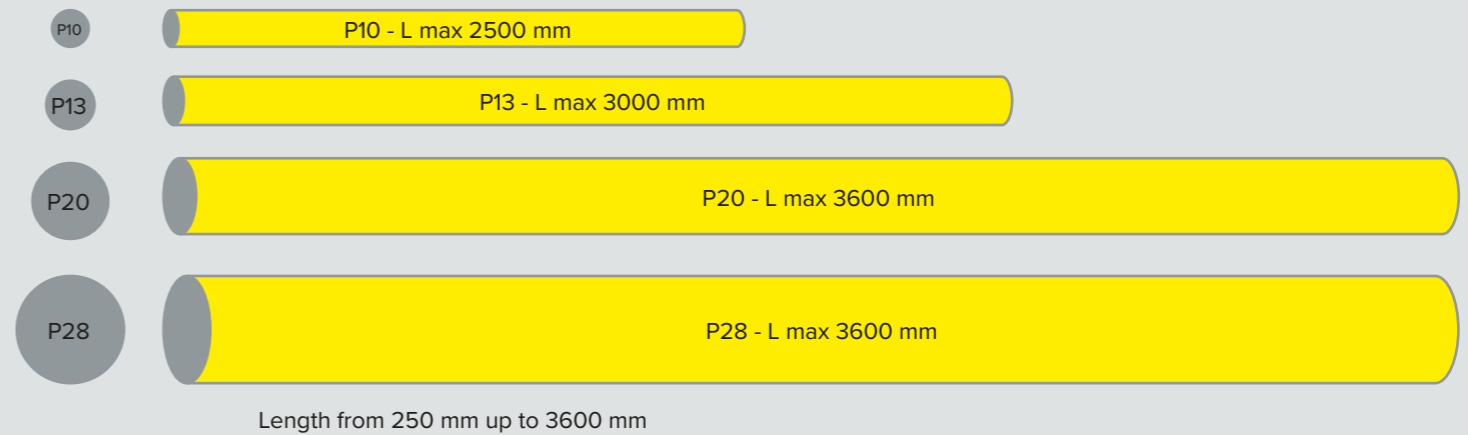
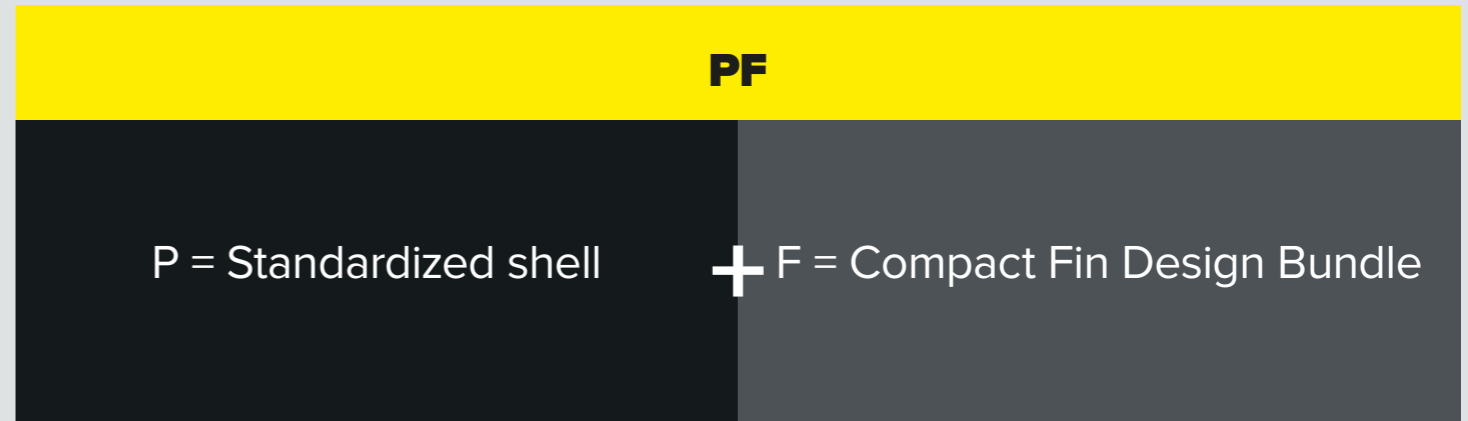

# PF COOLER OPTIONS

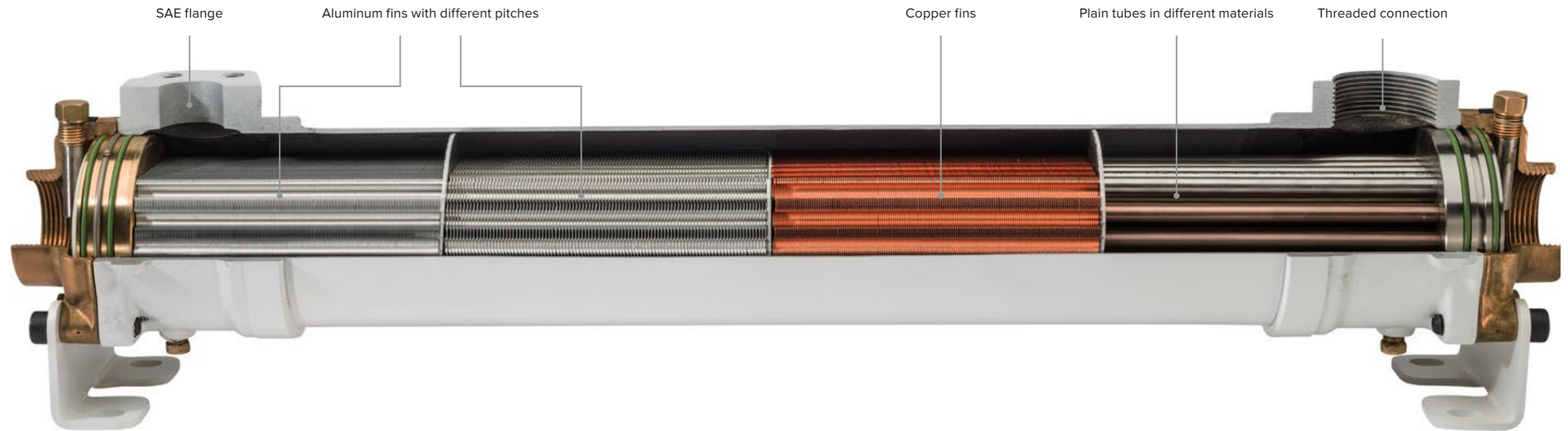

Media	
Shell side	Oil (lube, fuel, hydraulic), air
Tube side	Water (closed circuit water, clean water, open water or sea water)

Design	
Number of Types	4 shell diameters: 100 mm, 130 mm, 200 mm, 280 mm
Versions	Closed water circuits version and sea/surface water version
Length	250 - 3600 mm
Connections	BSP, DIN or SAE flanges
Tube side Passes	1 - 3
Mounting	To be mounted in every required position
Classification	Worldwide acceptance by all main marine classification societies

Design Data	Shell side	Tube side
Design Pressure	up to 25 bar(g)	10 bar(g)
Design temperature	up to 200 °C	up to 110 °C

Materials	
Tubes	Copper nickel 90/10, copper nickel 70/30 or stainless steel; optional inside phenolic coating
Covers	Cast Iron or bronze/brass with anodes
Shell	Nodular casting / carbon steel
Tube sheets	Seawater-resistant brass, carbon steel or stainless steel
O-ring	Viton or Neoprene
Fins	Aluminum, copper

Regulations and classifications	
USA	ABS (American Bureau of Shipping)
France	BV (Bureau Veritas, France)
China	CCS (China Classification Society)
Norway	DNV-GL (Det Norske Veritas, Norway)
Korea	KR (Korean Register of Shipping)
UK	LRS (Lloyds Register of Shipping)
Russia	RS (Russian Maritime Register of Shipping)
Japan	NK (Nippon Kaiji Kyokai)
Italy	RINA (Registro Italiano Navale)
Design Code	<b>AD2000</b>
<b>CE/PED approved construction</b>	

Features and benefits
Double O-ring construction: <ul style="list-style-type: none"> <li>No intermixing of fluids</li> </ul>
Easy inspection / cleaning on tube side
Flexible mounting: <ul style="list-style-type: none"> <li>Brackets adjustable (90° rotation steps)</li> <li>Fully adjustable brackets optional</li> </ul>
Shell diameter range from 100 to 280 mm
Variable fin pitch
Material execution in Marine Version (MV) or Industrial Version (IV)
Very compact tubular cooler, up to only 25% in size compared to conventional plain tube shell & tube heat exchangers
Low pressure drop on oil side
Non-welded construction
Low maintenance and operating costs
Easy to handle low weight tube bundle, removable from both sides
Easy cleaning on tube side
Only 4 pcs of O-rings and a minimum of bolting per cooler Shell side fluid can remain under pressure during overhaul on the tube side
Special cleaning sets available

# PFR TYPE

P-Type oil cooler for refrigeration applications

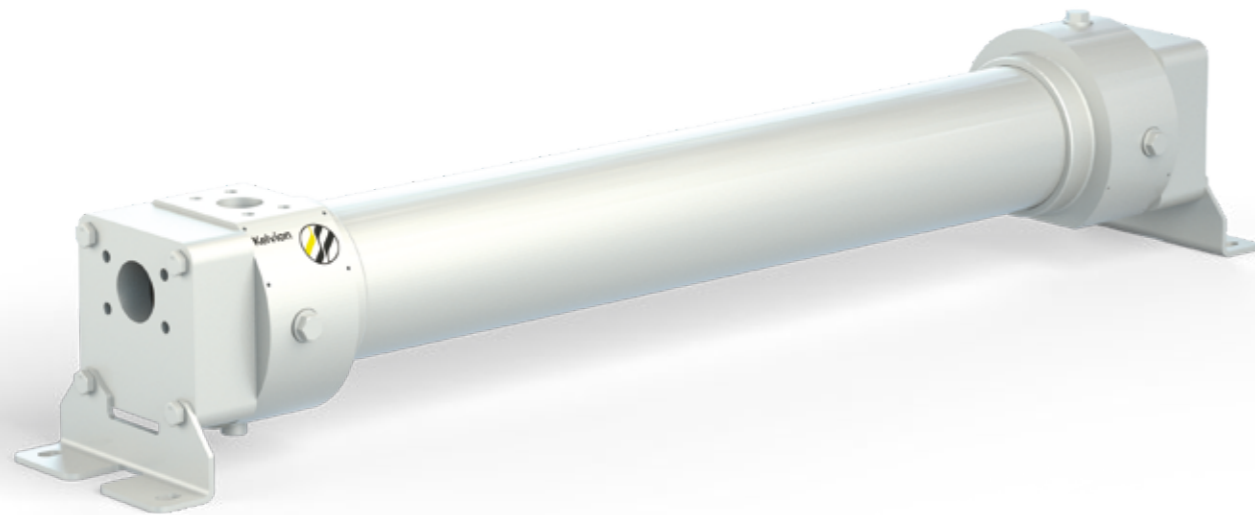

Within the P Series we also offer a special version for the refrigeration industry – the PFR Type.

It is ideal where the oil of screw compressors has to be cooled with another fluid applied in refrigeration systems. The oil, with some refrigerant, flows through the large surface of the compact fin stack of the cooler shell, while the non-oil fluid passes through the tube side of the stack with its smaller surface.

We have a model for closed-loop systems and, for more aggressive liquids, the cooler can be internally coated or equipped with sacrificial anodes and corrosion resistant materials, such as bronze. For thermosyphon applications, we developed a version to withstand 25 bar pressure on both the shell and the tube side. Here the media enter as liquids and evaporate on the tube side of the cooler.



# S&T SINGLE ComFin N SERIES



The S&T Single ComFin N-series is the right choice if the demand exceeds the maximum size, performance or construction features of the PF Type.

Like the P-series, the NF Type includes compact fin technology in the bundle. The difference is that the N-series has a customized, welded shell, which means that a wide variety of materials, construction and design codes can be applied.

The heat exchangers can be supplied as a single unit or with changeover valves and pipes in a heat exchanger set. We can also install the appropriate sensors to monitor your process.

**NF**

N = Customized shell

+ F = Compact Fin Design Bundle

The PF advantages which also apply to the NF type:

- Compact design
- Low pressure drop on the oil side
- Excellent mechanical resistance

Waterboxes with connections according to customer requirements

Shell with connections according to customer requirements

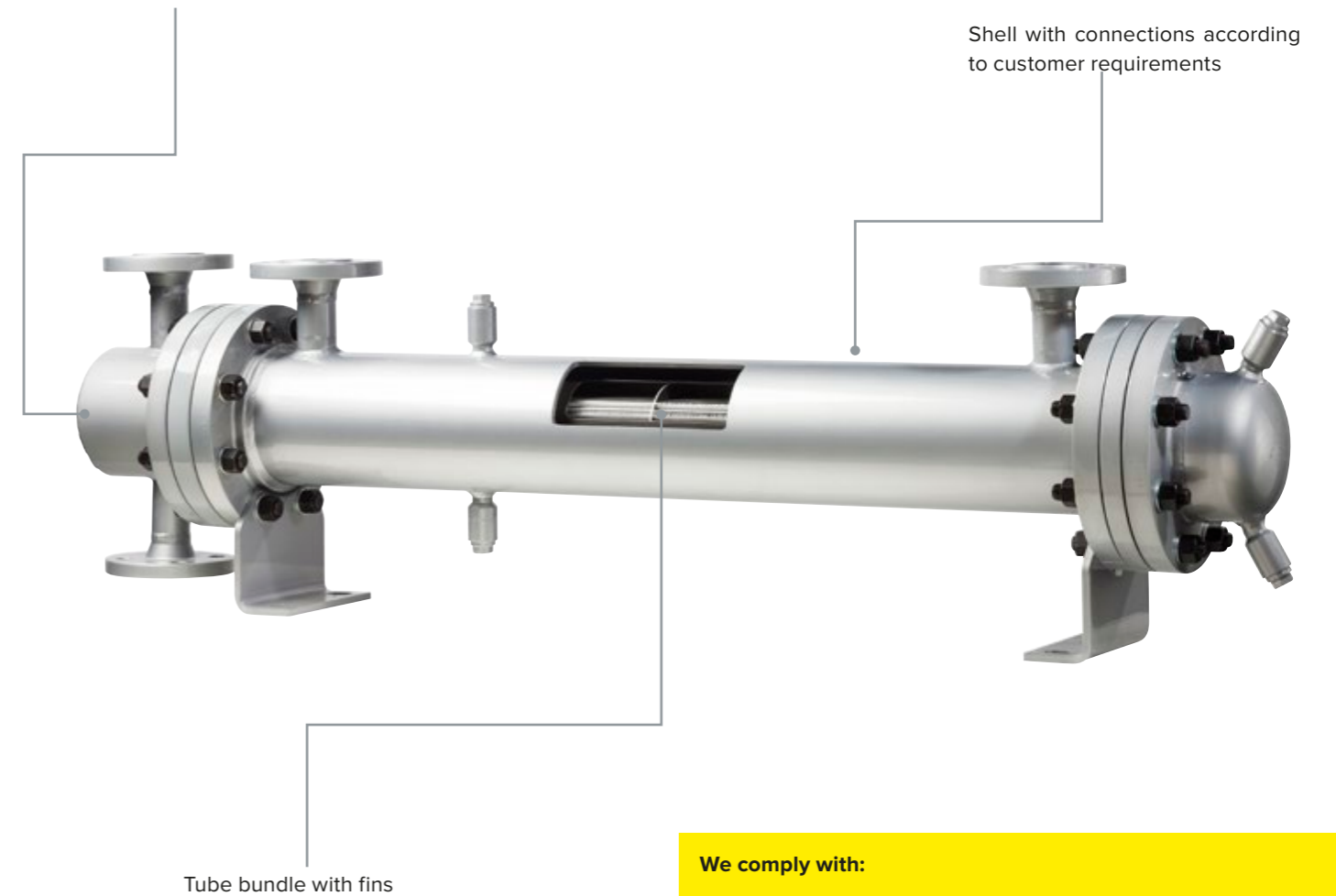

**We comply with:**

- Design pressures up to 30 barg on both sides
- Design temperatures up to 200 °C on shell side
- Design temperatures up to 120 °C on tube side
- Design according to ASME VIII-Div.1 / TEMA or AD 2000
- Ambient temperatures down to -29 °C at ASME design
- ASME Code stamp ( U )
- Large variety in connection dimensions and orientation

# S&T SINGLE ComFin SPECIAL SOLUTIONS

Our long-standing expertise, together with our extensive portfolio of standardized and custom-made products, means we can design tubular heat exchangers specifically for our customers' systems and installations.

To meet the demands of size, weight and performance, we have developed special cast cooler parts in cooperation with our customers. In some cases complete new combinations of materials were applied.

Our experienced R&D team is able to fulfil your customized heat exchanger requirements, validated by our testing facilities.



# S&T SINGLE ComFin INSERT BUNDLES

Where a complete heat exchanger is not required, we can offer you a bundle to install in your equipment, such as engine casings. The bundles come in a compact fin or a plain tube design, in a wide range of dimensions up to a diameter of 590 mm.



# RELATED PRODUCTS

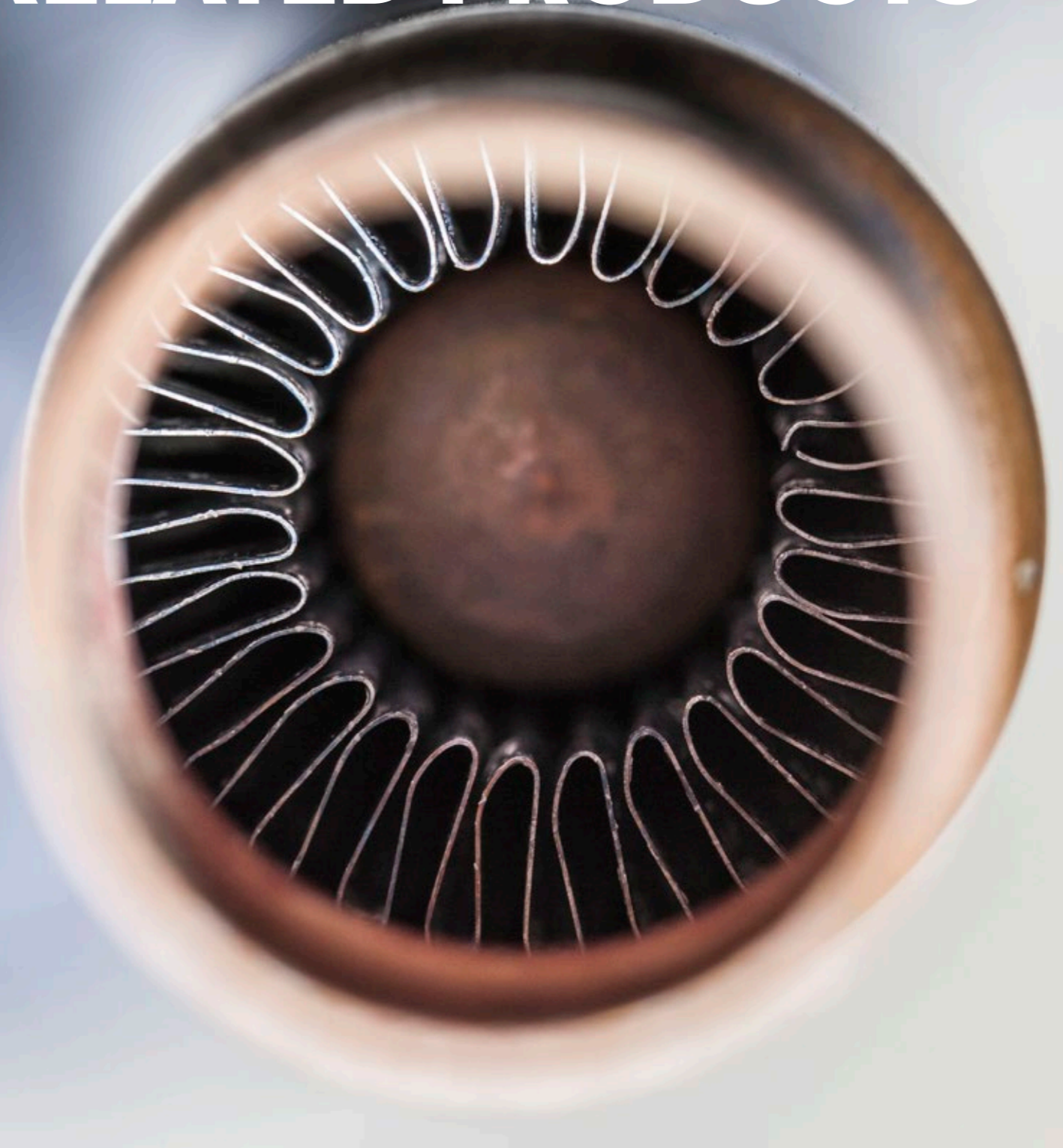

#### PIR Type

For special applications we are able to provide heat exchanger bundles with internal finned tubes.

#### PT/ NT types

Within the P-series and the N-series we are also able to offer you the bundle in a plain tube design. This is particularly suitable for exchanging heat between similar media, e.g. from water to water. The tube bundle of this heat exchanger can be manufactured in different materials, depending on the requirements of the application. Additionally different tube diameters can be applied.

#### PDT/ NDT types – The safety version

Both the P-series and the N-series can incorporate a double tube safety design. This type of heat exchanger is essential when the intermixing of fluid in the event of a leak must be strictly avoided.

# OUR SERVICE IN THREE WORDS: PEACE OF MIND



#### Kelvion offers:

- Maintenance contracts
- All activities after commissioning, including any mechanical/thermal upgrade
- All spare parts: non-proprietary equipment, mechanical equipment, gaskets, plates, rotating, etc.
- Replacements unless they are complete new components
- Refurbishment, partial replacement of any component on a heat exchanger, workshop and field services

#### After-sales & service

Developing and supplying products and solutions is one side of our business – comprehensive after-sales support and comprehensive services is the other. The most important aspect is always to satisfy your requirements. This principle has made us a highly reliable service specialist. Our tightly woven network of locations worldwide means we can offer our customers maximum availability everywhere and anytime.

#### We offer our customers the maximum degree of service, quality and reliability

The ideal support after a purchase is of paramount importance. For us at Kelvion, Service starts from our first contact with you and continues after your order has been delivered, with us as your reliable service partner. It does not end once your purchase has been delivered. Even after your purchase we remain available as your reliable service partner. We offer a wide range of after sales and service, with guaranteed trouble-free opera-

tion of your Kelvion heat exchanger. Our goal is to ensure the performance of your heat exchanger during operation and to extend the life cycle to the maximum.

With many years of experience in the field of service management, along with our Service Center, we can guarantee the satisfaction of our customers. Our digitized archive contains historical order data: because each heat exchanger has a unique drawing number we are able to ensure an accurate post-production search of your heat exchangers.

We provide you with full maintenance support for your equipment. The spectrum includes all after-sales and service from assembly through maintenance and spare part supply to preventative measures. Our highly qualified technicians lay the foundations for smooth operations with initial installation, modifications, repairs and commissioning.

#### Revision and repair

The condition of a heat exchanger can deteriorate over time. Inserts and channels can show signs of wear, which at some point need to be replaced. Kelvion is always available to advise you and carry out the necessary work. We provide the coordination, scheduling and project management should this be required.

By monitoring your heat exchanger's performance and operation on a regular basis, the life expectancy of your installation and process can be extended, which in turn results in lower operating costs.

#### Cleaning

Regular cleaning of your heat exchanger will maintain performance and ensure a continuous operation of your process. The return on investment (ROI) is easy to calculate because your operating costs decrease. During maintenance work the service engineer will advise you about a maintenance program.

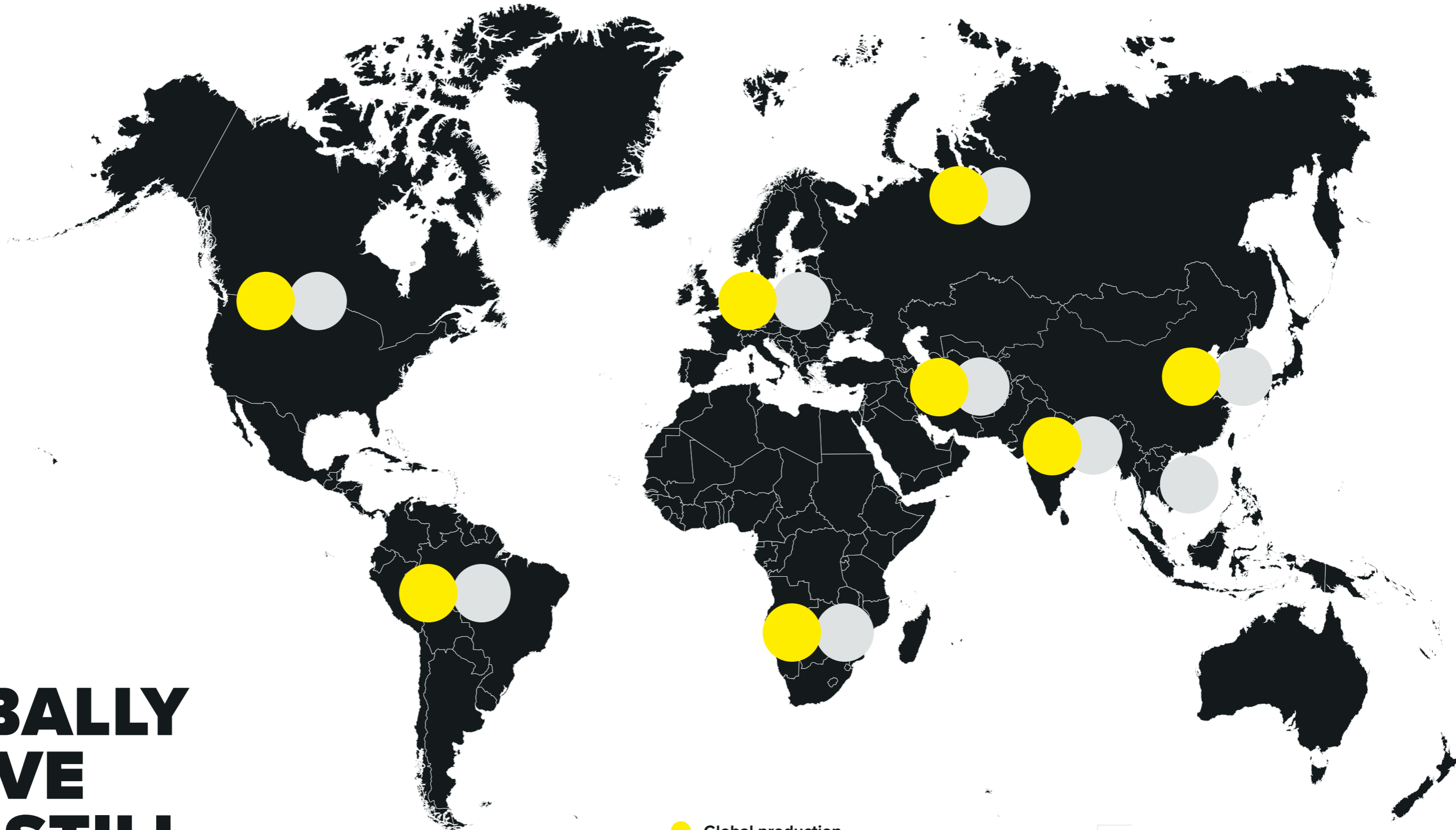

# GLOBALLY ACTIVE AND STILL CLOSE BY

No matter where your market is, regardless of country, we are never far away. We are always happy to answer any questions you may have and meet your requirements. Even the largest, most successful project begins with an initial, profitable conversation. We look forward to hearing from you.

- Global production footprint
- Global sales and service



Just scan this QR code with your smartphone or visit our website at: [www.kelvion.com](http://www.kelvion.com) – there you will find a highly competent contact in your immediate vicinity.

[www.kelvion.com](http://www.kelvion.com)